



Low Voltage Temperature Sensors

TMP35/TMP36/TMP37

FEATURES

- Low Voltage Operation (2.7 V to 5.5 V)
- Calibrated Directly in °C
- 10 mV/°C Scale Factor (20 mV/°C on TMP37)
- ±2°C Accuracy over Temperature (Typ)
- ±0.5°C Linearity (Typ)
- Stable with Large Capacitive Loads
- Specified -40°C to +125°C, Operation to +150°C
- Less than 50 µA Quiescent Current
- Shutdown Current 0.5 µA Max
- Low Self-Heating

APPLICATIONS

- Environmental Control Systems
- Thermal Protection
- Industrial Process Control
- Fire Alarms
- Power System Monitors
- CPU Thermal Management

PRODUCT DESCRIPTION

The TMP35, TMP36, and TMP37 are low voltage, precision centigrade temperature sensors. They provide a voltage output that is linearly proportional to the Celsius (Centigrade) temperature. The TMP35/TMP36/TMP37 do not require any external calibration to provide typical accuracies of ±1°C at +25°C and ±2°C over the -40°C to +125°C temperature range.

The low output impedance of the TMP35/TMP36/TMP37 and its linear output and precise calibration simplify interfacing to temperature control circuitry and A/D converters. All three devices are intended for single-supply operation from 2.7 V to 5.5 V maximum. Supply current runs well below 50 µA, providing very low self-heating—less than 0.1°C in still air. In addition, a shutdown function is provided to cut supply current to less than 0.5 µA.

The TMP35 is functionally compatible with the LM35/LM45 and provides a 250 mV output at 25°C. The TMP35 reads temperatures from 10°C to 125°C. The TMP36 is specified from -40°C to +125°C, provides a 750 mV output at 25°C, and operates to +125°C from a single 2.7 V supply. The TMP36 is functionally compatible with the LM50. Both the TMP35 and TMP36 have an output scale factor of 10 mV/°C. The TMP37 is intended for applications over the range 5°C to 100°C and provides an output scale factor of 20 mV/°C. The TMP37 provides a 500 mV output at 25°C. Operation extends to 150°C with reduced accuracy for all devices when operating from a 5 V supply.

The TMP35/TMP36/TMP37 are all available in low cost 3-lead TO-92, SOIC-8, and 5-lead SOT-23 surface-mount packages.

REV. C

Information furnished by Analog Devices is believed to be accurate and reliable. However, no responsibility is assumed by Analog Devices for its use, nor for any infringements of patents or other rights of third parties that may result from its use. No license is granted by implication or otherwise under any patent or patent rights of Analog Devices.

FUNCTIONAL BLOCK DIAGRAM

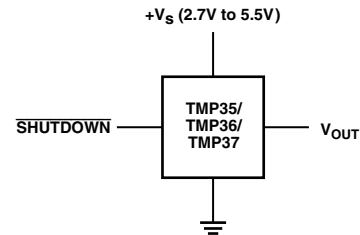

PACKAGE TYPES AVAILABLE

RT-5 (SOT-23)

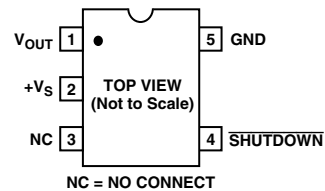

RN-8 (SOIC)

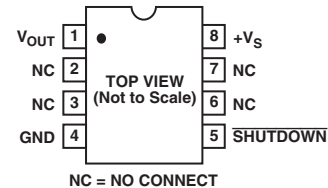

TO-92

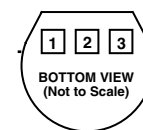

PIN 1, +V_S; PIN 2, V_{OUT}; PIN 3, GND

TMP35/TMP36/TMP37—SPECIFICATIONS¹ ($V_S = 2.7\text{ V to }5.5\text{ V}$, $-40^\circ\text{C} \leq T_A \leq +125^\circ\text{C}$, unless otherwise noted.)

Parameter	Symbol	Conditions	Min	Typ	Max	Unit
ACCURACY						
TMP35/TMP36/TMP37F		$T_A = 25^\circ\text{C}$		± 1	± 2	$^\circ\text{C}$
TMP35/TMP36/TMP37G		$T_A = 25^\circ\text{C}$		± 1	± 3	$^\circ\text{C}$
TMP35/TMP36/TMP37F		Over Rated Temperature		± 2	± 3	$^\circ\text{C}$
TMP35/TMP36/TMP37G		Over Rated Temperature		± 2	± 4	$^\circ\text{C}$
Scale Factor, TMP35		$10^\circ\text{C} \leq T_A \leq 125^\circ\text{C}$		10	9.8/10.2	$\text{mV}/^\circ\text{C}$
Scale Factor, TMP36		$-40^\circ\text{C} \leq T_A \leq +125^\circ\text{C}$		10	9.8/10.2	$\text{mV}/^\circ\text{C}$
Scale Factor, TMP37		$5^\circ\text{C} \leq T_A \leq 85^\circ\text{C}$		20	19.6/20.4	$\text{mV}/^\circ\text{C}$
		$5^\circ\text{C} \leq T_A \leq 100^\circ\text{C}$		20	19.6/20.4	$\text{mV}/^\circ\text{C}$
Load Regulation		$3.0\text{ V} \leq +V_S \leq 5.5\text{ V}$ $0\ \mu\text{A} \leq I_L \leq 50\ \mu\text{A}$ $-40^\circ\text{C} \leq T_A \leq +105^\circ\text{C}$		6	20	$\text{m}^\circ\text{C}/\mu\text{A}$
Power Supply Rejection Ratio	PSRR	$-105^\circ\text{C} \leq T_A \leq +125^\circ\text{C}$ $T_A = 25^\circ\text{C}$		25	60	$\text{m}^\circ\text{C}/\mu\text{A}$
Linearity		$3.0\text{ V} \leq +V_S \leq 5.5\text{ V}$		30	100	$\text{m}^\circ\text{C}/\text{V}$
Long-Term Stability		$T_A = 150^\circ\text{C}$ for 1 kHrs		50		$\text{m}^\circ\text{C}/\text{V}$
				0.5		$^\circ\text{C}$
				0.4		$^\circ\text{C}$
SHUTDOWN						
Logic High Input Voltage	V_{IH}	$V_S = 2.7\text{ V}$	1.8			V
Logic Low Input Voltage	V_{IL}	$V_S = 5.5\text{ V}$			400	mV
OUTPUT						
TMP35 Output Voltage		$T_A = 25^\circ\text{C}$		250		mV
TMP36 Output Voltage		$T_A = 25^\circ\text{C}$		750		mV
TMP37 Output Voltage		$T_A = 25^\circ\text{C}$		500		mV
Output Voltage Range			100		2000	mV
Output Load Current	I_L		0		50	μA
Short-Circuit Current	I_{SC}	Note 2			250	μA
Capacitive Load Driving	C_L	No Oscillations ²	1000	10000		pF
Device Turn-On Time		Output within $\pm 1^\circ\text{C}$ 100 k Ω 100 pF Load ²		0.5	1	ms
POWER SUPPLY						
Supply Range	$+V_S$		2.7		5.5	V
Supply Current	$I_{SY(ON)}$	Unloaded			50	μA
Supply Current (Shutdown)	$I_{SY(OFF)}$	Unloaded		0.01	0.5	μA

NOTES

¹Does not consider errors caused by self-heating.

²Guaranteed but not tested.

Specifications subject to change without notice.

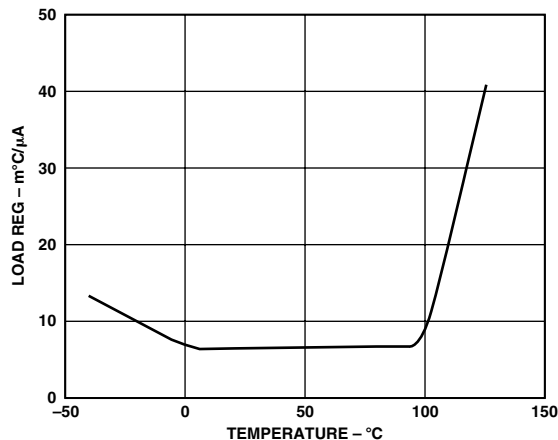

Figure 1. Load Reg vs. Temperature ($\text{m}^\circ\text{C}/\mu\text{A}$)

TMP35/TMP36/TMP37

ABSOLUTE MAXIMUM RATINGS^{1, 2, 3}

Supply Voltage	7 V
Shutdown Pin	$GND \leq \overline{SHUTDOWN} \leq +V_S$
Output Pin	$GND \leq V_{OUT} \leq +V_S$
Operating Temperature Range	-55°C to +150°C
Dice Junction Temperature	175°C
Storage Temperature Range	-65°C to +160°C
Lead Temperature (Soldering, 60 sec)	300°C

NOTES

¹Stresses above those listed under Absolute Maximum Ratings may cause permanent damage to the device. This is a stress rating only; functional operation at or above this specification is not implied. Exposure to maximum rating conditions for extended periods may affect device reliability.

²Digital inputs are protected; however, permanent damage may occur on unprotected units from high energy electrostatic fields. Keep units in conductive foam or packaging at all times until ready to use. Use proper antistatic handling procedures.

³Remove power before inserting or removing units from their sockets.

Package Type	θ_{JA}	θ_{JC}	Unit
TO-92 (T9 Suffix)	162	120	°C/W
SOIC-8 (S Suffix)	158	43	°C/W
SOT-23 (RT Suffix)	300	180	°C/W

θ_{JA} is specified for device in socket (worst-case conditions).

ORDERING GUIDE

Model	Accuracy at 25°C (°C max)	Linear Operating Temperature Range	Package Options ¹
TMP35FT9	±2.0	10°C to 125°C	TO-92
TMP35GT9	±3.0	10°C to 125°C	TO-92
TMP35FS	±2.0	10°C to 125°C	RN-8
TMP35GS	±3.0	10°C to 125°C	RN-8
TMP35GRT ²	±3.0	10°C to 125°C	RT-5
TMP36FT9	±2.0	-40°C to +125°C	TO-92
TMP36GT9	±3.0	-40°C to +125°C	TO-92
TMP36FS	±2.0	-40°C to +125°C	RN-8
TMP36GS	±3.0	-40°C to +125°C	RN-8
TMP36GRT ²	±3.0	-40°C to +125°C	RT-5
TMP37FT9	±2.0	5°C to 100°C	TO-92
TMP37GT9	±3.0	5°C to 100°C	TO-92
TMP37FS	±2.0	5°C to 100°C	RN-8
TMP37GS	±3.0	5°C to 100°C	RN-8
TMP37GRT ²	±3.0	5°C to 100°C	RT-5

NOTES

¹SOIC = Small Outline Integrated Circuit; RT = Plastic Surface Mount; TO = Plastic.

²Consult factory for availability.

FUNCTIONAL DESCRIPTION

An equivalent circuit for the TMP3x family of micropower, centigrade temperature sensors is shown in Figure 2. At the heart of the temperature sensor is a band gap core, which is comprised of transistors Q1 and Q2, biased by Q3 to approximately 8 μ A. The band gap core operates both Q1 and Q2 at the same collector current level; however, since the emitter area of Q1 is 10 times that of Q2, Q1's V_{BE} and Q2's V_{BE} are not equal by the following relationship:

$$\Delta V_{BE} = V_T \times \ln \left(\frac{A_{E,Q1}}{A_{E,Q2}} \right)$$

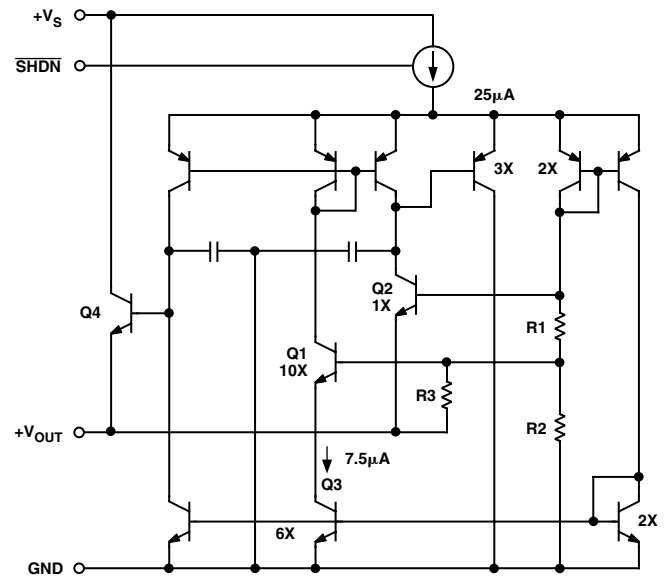

Figure 2. Temperature Sensor Simplified Equivalent Circuit

Resistors R1 and R2 are used to scale this result to produce the output voltage transfer characteristic of each temperature sensor and, simultaneously, R2 and R3 are used to scale Q1's V_{BE} as an offset term in V_{OUT} . Table I summarizes the differences between the three temperature sensors' output characteristics.

Table I. TMP3x Output Characteristics

Sensor	Offset Voltage (V)	Output Voltage Scaling (mV/°C)	Output Voltage @ 25°C (mV)
TMP35	0	10	250
TMP36	0.5	10	750
TMP37	0	20	500

The output voltage of the temperature sensor is available at the emitter of Q4, which buffers the band gap core and provides load current drive. Q4's current gain, working with the available base current drive from the previous stage, sets the short-circuit current limit of these devices to 250 μ A.

CAUTION

ESD (electrostatic discharge) sensitive device. Electrostatic charges as high as 4000 V readily accumulate on the human body and test equipment and can discharge without detection. Although the TMP35/TMP36/TMP37 features proprietary ESD protection circuitry, permanent damage may occur on devices subjected to high energy electrostatic discharges. Therefore, proper ESD precautions are recommended to avoid performance degradation or loss of functionality.



TMP35/TMP36/TMP37 – Typical Performance Characteristics

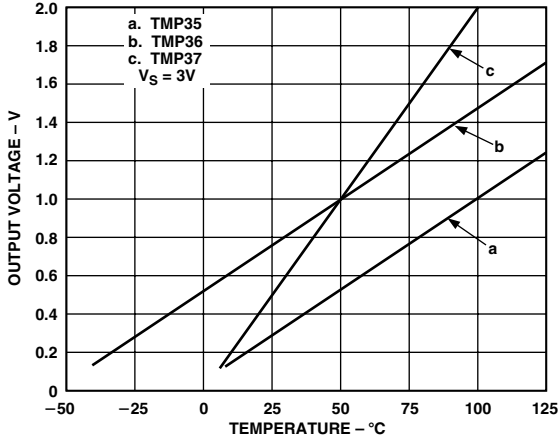

TPC 1. Output Voltage vs. Temperature

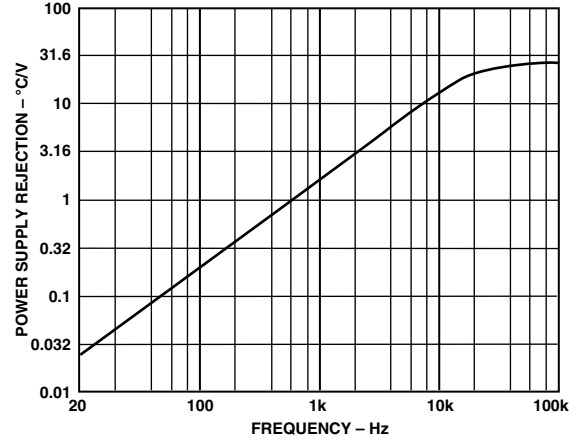

TPC 4. Power Supply Rejection vs. Frequency

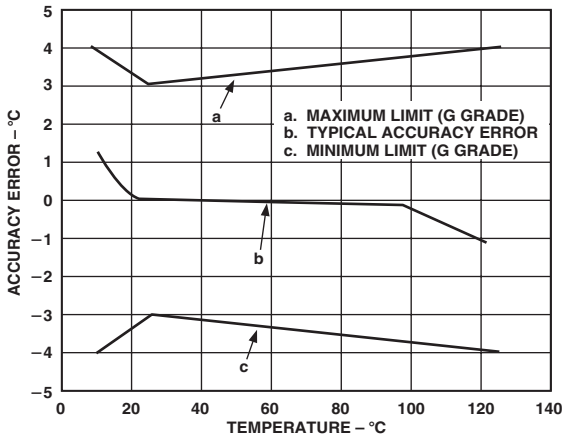

TPC 2. Accuracy Error vs. Temperature

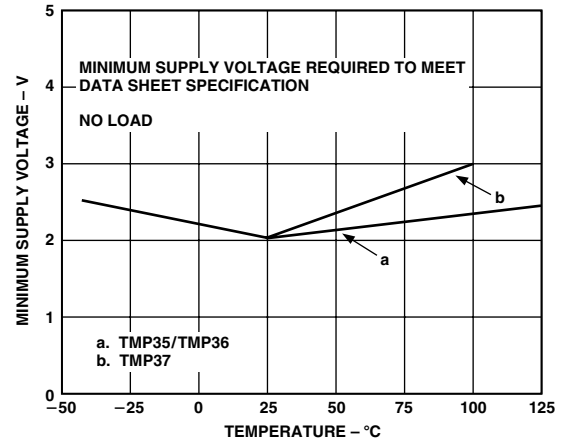

TPC 5. Minimum Supply Voltage vs. Temperature

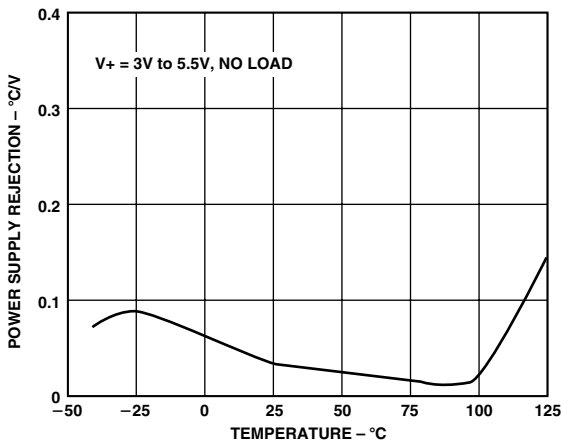

TPC 3. Power Supply Rejection vs. Temperature

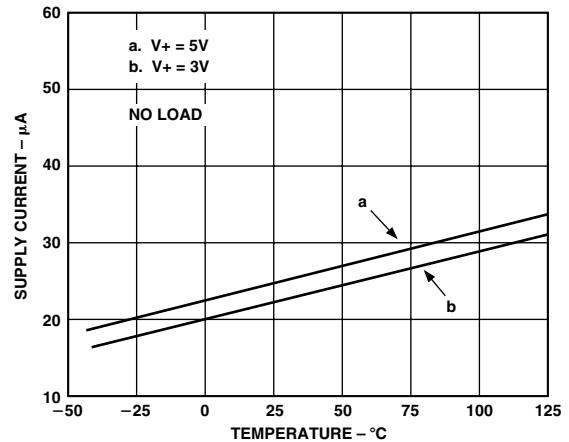

TPC 6. Supply Current vs. Temperature

TMP35/TMP36/TMP37

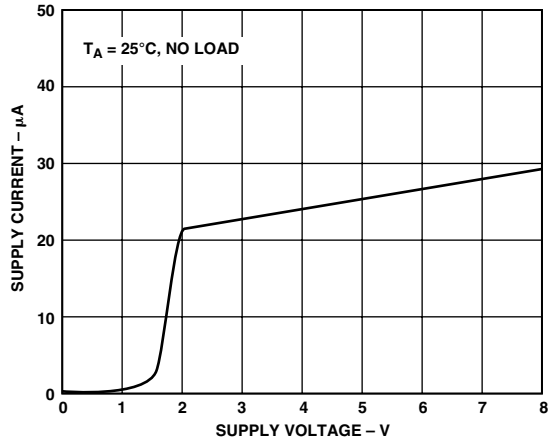

TPC 7. Supply Current vs. Supply Voltage

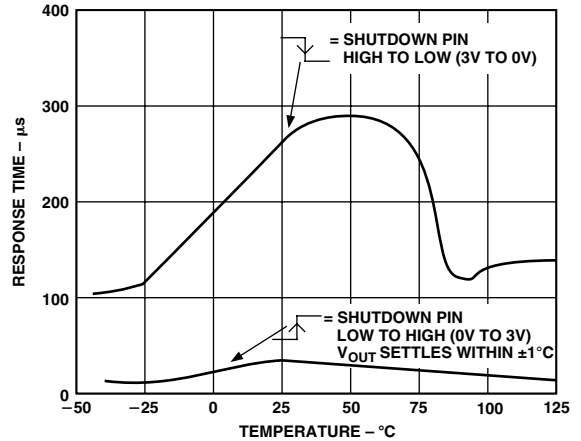

TPC 10. V_{OUT} Response Time for Shutdown Pin vs. Temperature

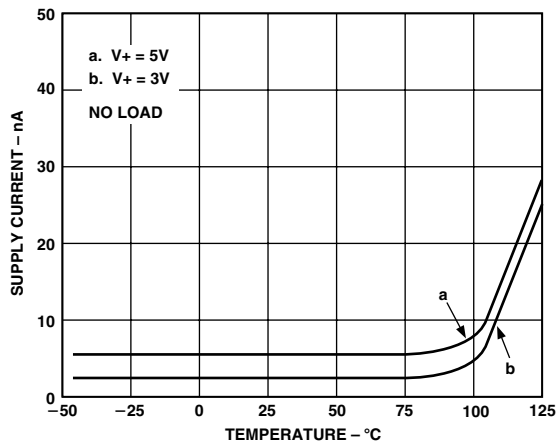

TPC 8. Supply Current vs. Temperature (Shutdown = 0 V)

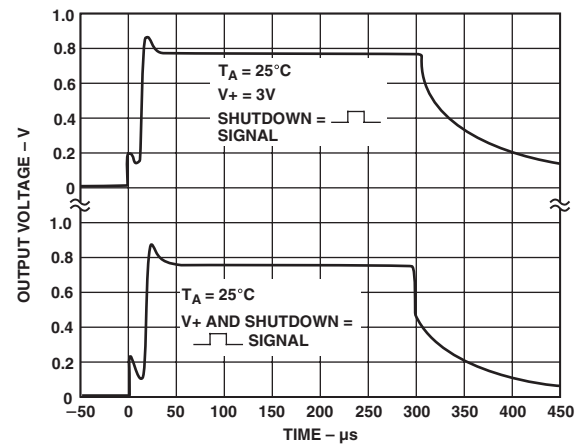

TPC 11. V_{OUT} Response Time to Shutdown and $V+$ Pins vs. Time

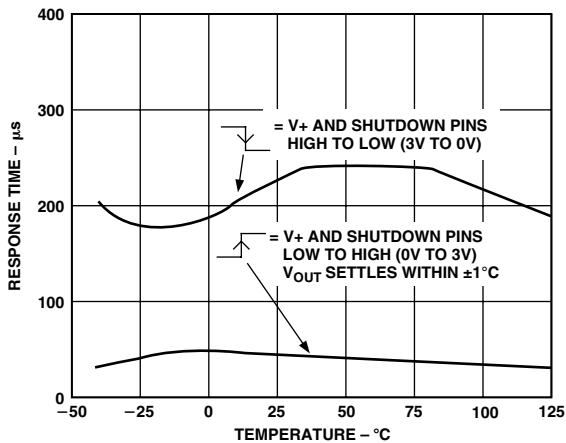

TPC 9. V_{OUT} Response Time for $V+$ Power-Up/Power-Down vs. Temperature

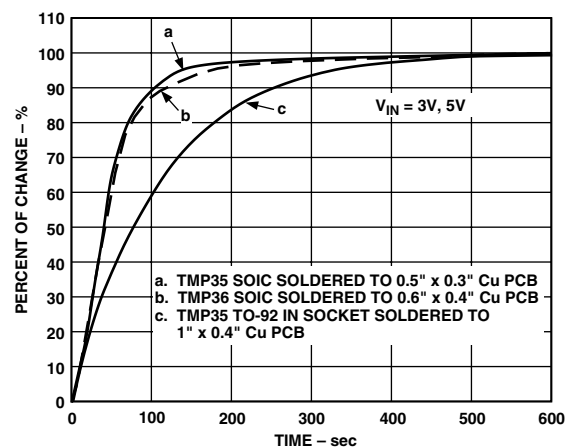

TPC 12. Thermal Response Time in Still Air

TMP35/TMP36/TMP37

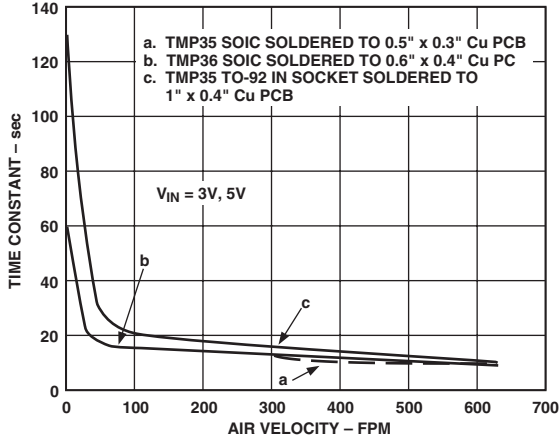

TPC 13. Thermal Response Time Constant in Forced Air

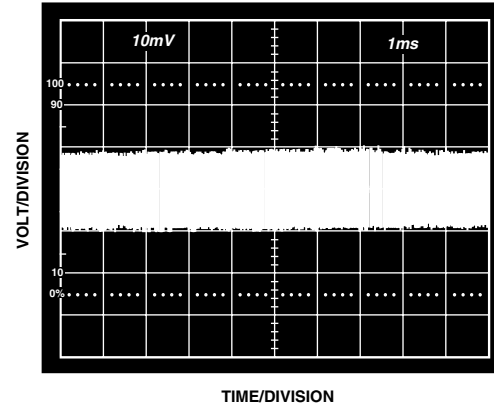

TPC 15. Temperature Sensor Wideband Output Noise Voltage. Gain = 100, BW = 157 kHz

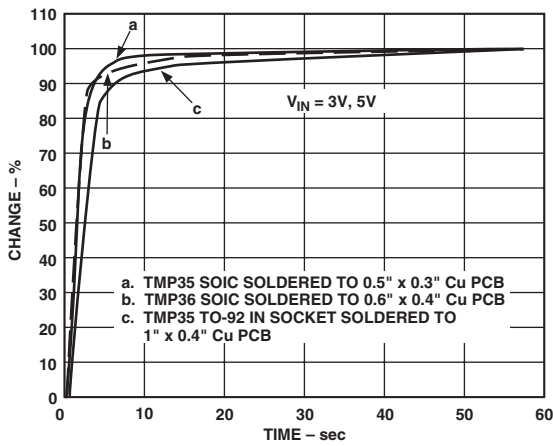

TPC 14. Thermal Response Time in Stirred Oil Bath

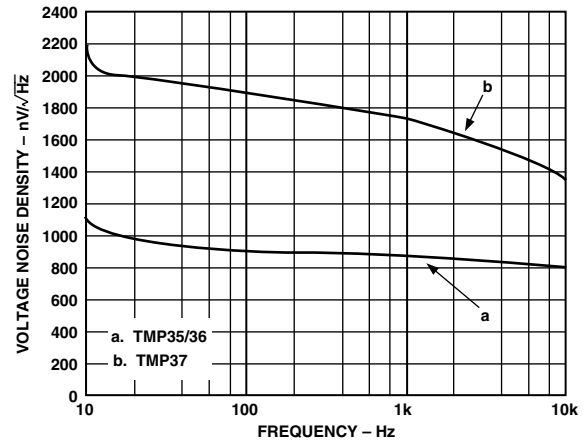

TPC 16. Voltage Noise Spectral Density vs. Frequency

TMP35/TMP36/TMP37

APPLICATIONS SECTION

Shutdown Operation

All TMP3x devices include a shutdown capability that reduces the power supply drain to less than 0.5 μA maximum. This feature, available only in the SOIC-8 and the SOT-23 packages, is TTL/CMOS level compatible, provided that the temperature sensor supply voltage is equal in magnitude to the logic supply voltage. Internal to the TMP3x at the SHUTDOWN pin, a pull-up current source to V_{IN} is connected. This permits the SHUTDOWN pin to be driven from an open-collector/drain driver. A logic LOW, or zero-volt condition on the SHUTDOWN pin, is required to turn the output stage OFF. During shutdown, the output of the temperature sensors becomes a high impedance state where the potential of the output pin would then be determined by external circuitry. If the shutdown feature is not used, it is recommended that the SHUTDOWN pin be connected to V_{IN} (Pin 8 on the SOIC-8, Pin 2 on the SOT-23).

The shutdown response time of these temperature sensors is illustrated in TPCs 9, 10, and 11.

Mounting Considerations

If the TMP3x temperature sensors are thermally attached and protected, they can be used in any temperature measurement application where the maximum temperature range of the medium is between -40°C to $+125^{\circ}\text{C}$. Properly cemented or glued to the surface of the medium, these sensors will be within 0.01°C of the surface temperature. Caution should be exercised, especially with TO-92 packages, because the leads and any wiring to the device can act as heat pipes, introducing errors if the surrounding air-surface interface is not isothermal. Avoiding this condition is easily achieved by dabbing the leads of the temperature sensor and the hookup wires with a bead of thermally conductive epoxy. This will ensure that the TMP3x die temperature is not affected by the surrounding air temperature.

Because plastic IC packaging technology is used, excessive mechanical stress should be avoided when fastening the device with a clamp or a screw-on heat tab. Thermally conductive epoxy or glue, which must be electrically nonconductive, is recommended under typical mounting conditions.

These temperature sensors, as well as any associated circuitry, should be kept insulated and dry to avoid leakage and corrosion. In wet or corrosive environments, any electrically isolated metal or ceramic well can be used to shield the temperature sensors. Condensation at very cold temperatures can cause errors and should be avoided by sealing the device, using electrically nonconductive epoxy paints or dip or any one of many printed circuit board coatings and varnishes.

Thermal Environment Effects

The thermal environment in which the TMP3x sensors are used determines two important characteristics: self-heating effects and thermal response time. Illustrated in Figure 3 is a thermal model of the TMP3x temperature sensors that is useful in understanding these characteristics.

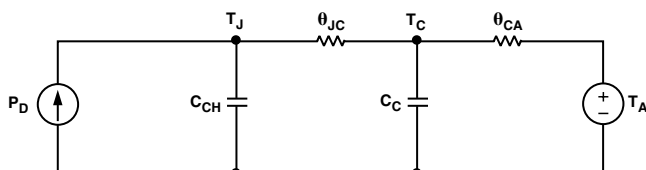

Figure 3. Thermal Circuit Model

In the TO-92 package, the thermal resistance junction-to-case, θ_{JC} , is $120^{\circ}\text{C}/\text{W}$. The thermal resistance case-to-ambient, θ_{CA} , is the difference between θ_{JA} and θ_{JC} , and is determined by the characteristics of the thermal connection. The temperature sensor's power dissipation, represented by P_{D} , is the product of the total voltage across the device and its total supply current (including any current delivered to the load). The rise in die temperature above the medium's ambient temperature is given by:

$$T_j = P_D \times (\theta_{\text{JC}} + \theta_{\text{CA}}) + T_A$$

Thus, the die temperature rise of a TMP35 "RT" package mounted into a socket in still air at 25°C and driven from a 5 V supply is less than 0.04°C .

The transient response of the TMP3x sensors to a step change in the temperature is determined by the thermal resistances and the thermal capacities of the die, C_{CH} , and the case, C_{C} . The thermal capacity of the case, C_{C} , varies with the measurement medium since it includes anything in direct contact with the package. In all practical cases, the thermal capacity of the case is the limiting factor in the thermal response time of the sensor and can be represented by a single-pole RC time constant response. TPCs 12 and 14 illustrate the thermal response time of the TMP3x sensors under various conditions. The thermal time constant of a temperature sensor is defined as the time required for the sensor to reach 63.2% of the final value for a step change in the temperature. For example, the thermal time constant of a TMP35 "S" package sensor mounted onto a 0.5" by 0.3" PCB is less than 50 sec in air, whereas in a stirred oil bath, the time constant is less than 3 seconds.

Basic Temperature Sensor Connections

Figure 4 illustrates the basic circuit configuration for the TMP3x family of temperature sensors. The table shown in the figure illustrates the pin assignments of the temperature sensors for the three package types. For the SOT-23, Pin 3 is labeled as "NC" as are Pins 2, 3, 6, and 7 on the SOIC-8 package. It is recommended that no electrical connections be made to these pins. If the shutdown feature is not needed on the SOT-23 or the SOIC-8 package, the SHUTDOWN pin should be connected to V_{S} .

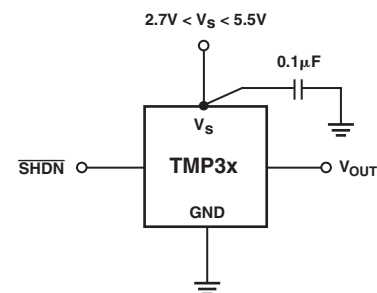

PIN ASSIGNMENTS

PACKAGE	V_{S}	GND	V_{OUT}	SHDN
SOIC-8	8	4	1	5
SOT-23-5	2	5	1	4
TO-92	1	3	2	NA

Figure 4. Basic Temperature Sensor Circuit Configuration

TMP35/TMP36/TMP37

Note the 0.1 μF bypass capacitor on the input. This capacitor should be a ceramic type, have very short leads (surface mount would be preferable), and be located as close a physical proximity to the temperature sensor supply pin as practical. Since these temperature sensors operate on very little supply current and could be exposed to very hostile electrical environments, it is important to minimize the effects of RFI (radio frequency interference) on these devices. The effect of RFI on these temperature sensors in specific and analog ICs in general is manifested as abnormal dc shifts in the output voltage due to the rectification of the high frequency ambient noise by the IC. In those cases where the devices are operated in the presence of high frequency radiated or conducted noise, a large value tantalum capacitor (>2.2 μF) placed across the 0.1 μF ceramic may offer additional noise immunity.

Fahrenheit Thermometers

Although the TMP3x temperature sensors are centigrade temperature sensors, a few components can be used to convert the output voltage and transfer characteristics to directly read Fahrenheit temperatures. Shown in Figure 5a is an example of a simple Fahrenheit thermometer using either the TMP35 or the TMP37. This circuit can be used to sense temperatures from 41°F to 257°F, with an output transfer characteristic of 1 mV/°F using the TMP35 and from 41°F to 212°F using the TMP37 with an output characteristic of 2 mV/°F. This particular approach does not lend itself well to the TMP36 because of its inherent 0.5 V output offset. The circuit is constructed with an AD589, a 1.23 V voltage reference, and four resistors whose values for each sensor are shown in the figure table. The scaling of the output resistance levels was to ensure minimum output loading on the temperature sensors. A generalized expression for the circuit's transfer equation is given by:

$$V_{OUT} = \left(\frac{R1}{R1 + R2} \right) (TMP35) + \left(\frac{R3}{R3 + R4} \right) (AD589)$$

where: *TMP35* = Output voltage of the TMP35, or the TMP37, at the measurement temperature, *T_M*, and
AD589 = Output voltage of the reference = 1.23 V.

Note that the output voltage of this circuit is not referenced to the circuit's common. If this output voltage were to be applied directly to the input of an ADC, the ADC's common should be adjusted accordingly.

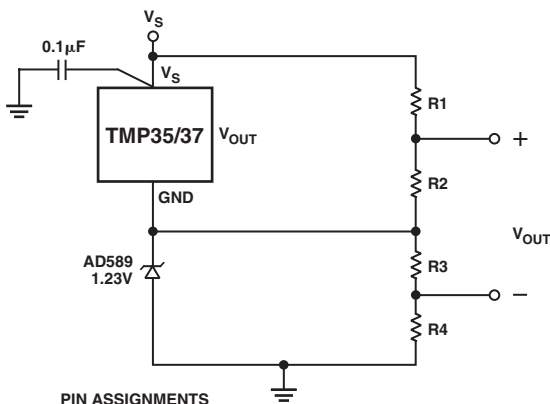

PIN ASSIGNMENTS

SENSOR	TCV _{OUT}	R1 (kΩ)	R2 (kΩ)	R3 (kΩ)	R4 (kΩ)
TMP35	1mV/°F	45.3	10	10	374
TMP37	2mV/°F	45.3	10	10	182

Figure 5a. TMP35/TMP37 Fahrenheit Thermometers

The same circuit principles can be applied to the TMP36, but because of the TMP36's inherent offset, the circuit uses two less resistors as shown in Figure 5b. In this circuit, the output voltage transfer characteristic is 1 mV/°F but is referenced to the circuit's common; however, there is a 58 mV (58°F) offset in the output voltage. For example, the output voltage of the circuit would read 18 mV were the TMP36 placed in -40°F ambient environment and 315 mV at 257°F.

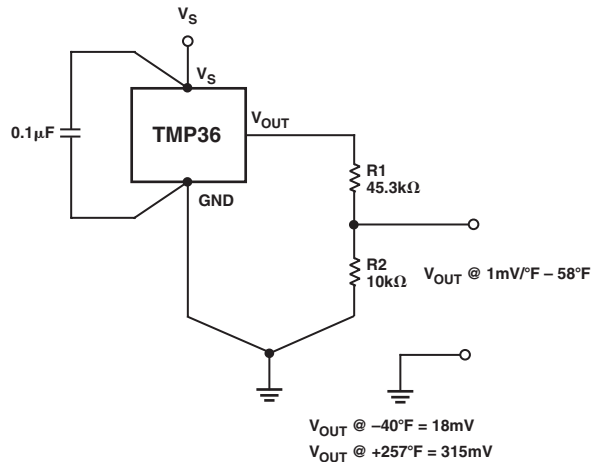

Figure 5b. TMP36 Fahrenheit Thermometer Version 1

At the expense of additional circuitry, the offset produced by the circuit in Figure 5b can be avoided by using the circuit in Figure 5c. In this circuit, the output of the TMP36 is conditioned by a single-supply, micropower op amp, the OP193. Although the entire circuit operates from a single 3 V supply, the output voltage of the circuit reads the temperature directly, with a transfer characteristic of 1 mV/°F, without offset. This is accomplished through the use of an ADM660, a supply voltage inverter. The 3 V supply is inverted and applied to the P193's V- terminal. Thus, for a temperature range between -40°F and +257°F, the output of the circuit reads -40 mV to +257 mV. A general expression for the circuit's transfer equation is given by:

$$V_{OUT} = \left(\frac{R6}{R5 + R6} \right) \left(1 + \frac{R4}{R3} \right) (TMP36) - \left(\frac{R4}{R3} \right) \left(\frac{V_S}{2} \right)$$

Average and Differential Temperature Measurement

In many commercial and industrial environments, temperature sensors are often used to measure the average temperature in a building, or the difference in temperature between two locations on a factory floor or in an industrial process. The circuits in Figures 6a and 6b demonstrate an inexpensive approach to average and differential temperature measurement. In Figure 6a, an OP193 is used to sum the outputs of three temperature sensors to produce an output voltage scaled by 10 mV/°C that represents the average temperature at three locations. The circuit can be extended to as many temperature sensors as required as long as the circuit's transfer equation is maintained. In this application, it is recommended that one temperature sensor type be used throughout the circuit; otherwise, the output voltage of the circuit will not produce an accurate reading of the various ambient conditions.

TMP35/TMP36/TMP37

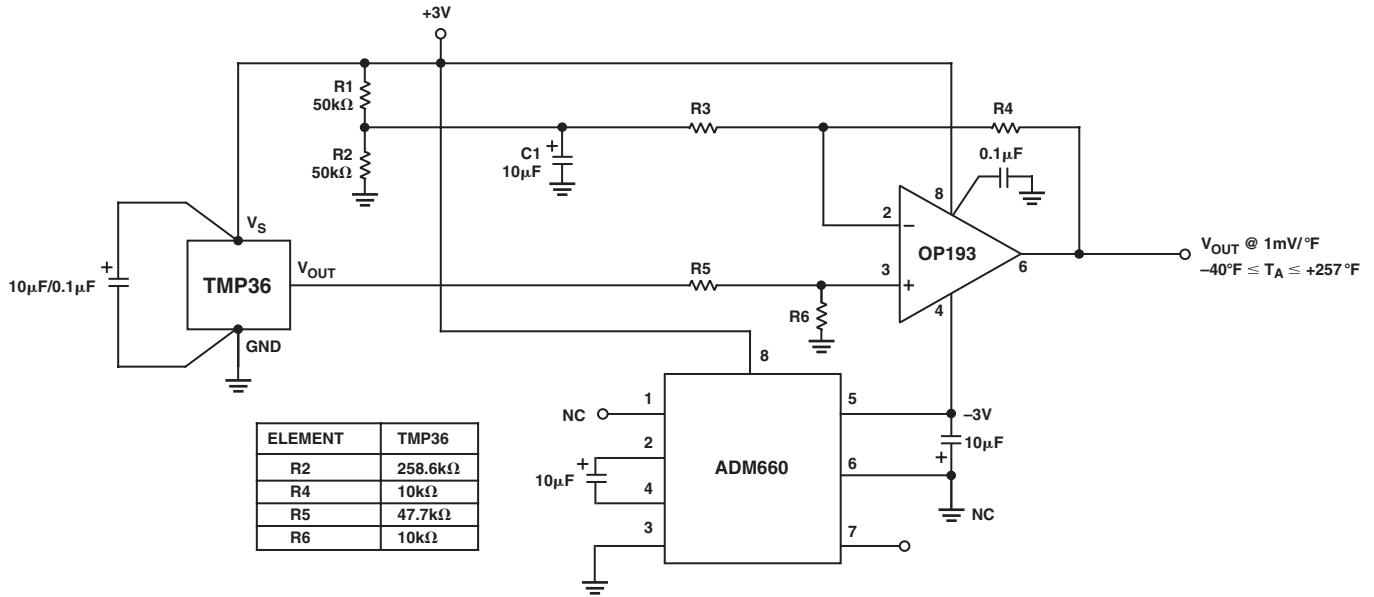

Figure 5c. TMP36 Fahrenheit Thermometer Version 2

The circuit in Figure 6b illustrates how a pair of TMP3x sensors can be used with an OP193 configured as a difference amplifier to read the difference in temperature between two locations. In these applications, it is always possible that one temperature sensor would be reading a temperature below that of the other sensor. To accommodate this condition, the output of the OP193 is offset to a voltage at one-half the supply via R5 and R6. Thus, the output voltage of the circuit is measured relative to this point,

as shown in the figure. Using the TMP36, the output voltage of the circuit is scaled by 10 mV/°C. To minimize error in the difference between the two measured temperatures, a common, readily available thin-film resistor network is used for R1–R4.

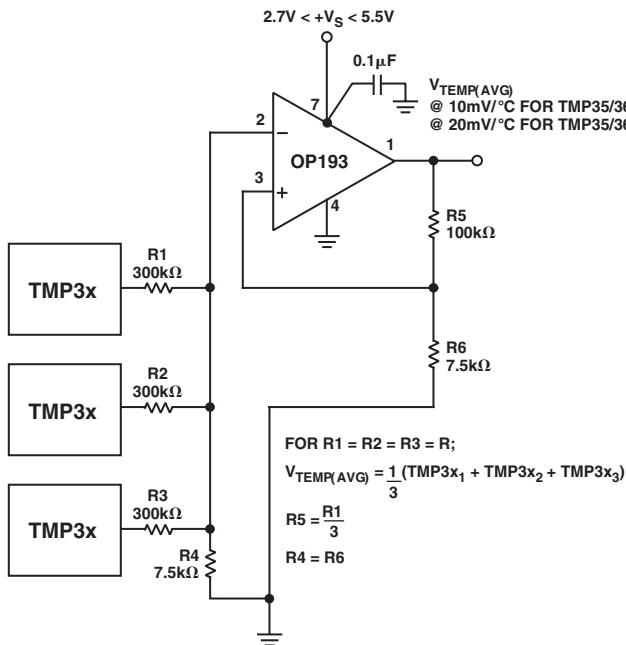

Figure 6a. Configuring Multiple Sensors for Average Temperature Measurements

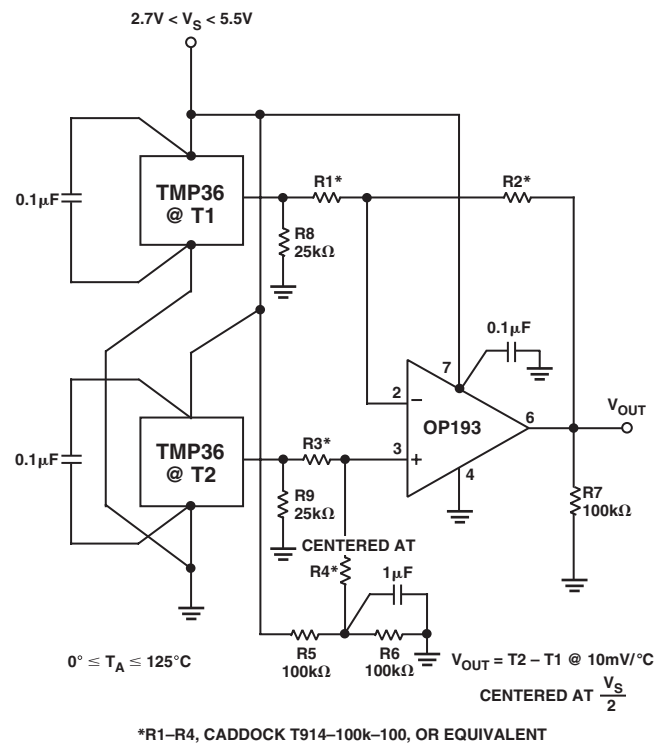

Figure 6b. Configuring Multiple Sensors for Differential Temperature Measurements

TMP35/TMP36/TMP37

Microprocessor Interrupt Generator

These inexpensive temperature sensors can be used with a voltage reference and an analog comparator to configure an interrupt generator useful in microprocessor applications. With the popularity of fast 486 and Pentium® laptop computers, the need to indicate a microprocessor overtemperature condition has grown tremendously. The circuit illustrated in Figure 7 demonstrates one way to generate an interrupt using a TMP35, a CMP402 analog comparator, and a REF191, a 2 V precision voltage reference.

The circuit has been designed to produce a logic HIGH interrupt signal if the microprocessor temperature exceeds 80°C. This 80°C trip point was arbitrarily chosen (final value set by the microprocessor thermal reference design) and is set using an R3–R4 voltage divider of the REF191's output voltage. Since the output of the TMP35 is scaled by 10 mV/°C, the voltage at the CMP402's inverting terminal is set to 0.8 V.

Since temperature is a slowly moving quantity, the possibility for comparator chatter exists. To avoid this condition, hysteresis is used around the comparator. In this application, a hysteresis of 5°C about the trip point was arbitrarily chosen; the ultimate value for hysteresis should be determined by the end application. The output logic voltage swing of the comparator with R1 and R2 determine the amount of comparator hysteresis. Using a 3.3 V supply, the output logic voltage swing of the CMP402 is 2.6 V; thus, for a hysteresis of 5°C (50 mV @ 10 mV/°C), R1 is set to 20 kΩ and R2 is set to 1 MΩ. An expression for this circuit's hysteresis is given by:

$$V_{HYS} = \left(\frac{R1}{R2} \right) (V_{LOGIC SWING, CMP402})$$

Because of the likelihood that this circuit would be used in close proximity to high speed digital circuits, R1 is split into equal values and a 1000 pF is used to form a low-pass filter on the output of the TMP35. Furthermore, to prevent high frequency noise from contaminating the comparator trip point, a 0.1 μF capacitor is used across R4.

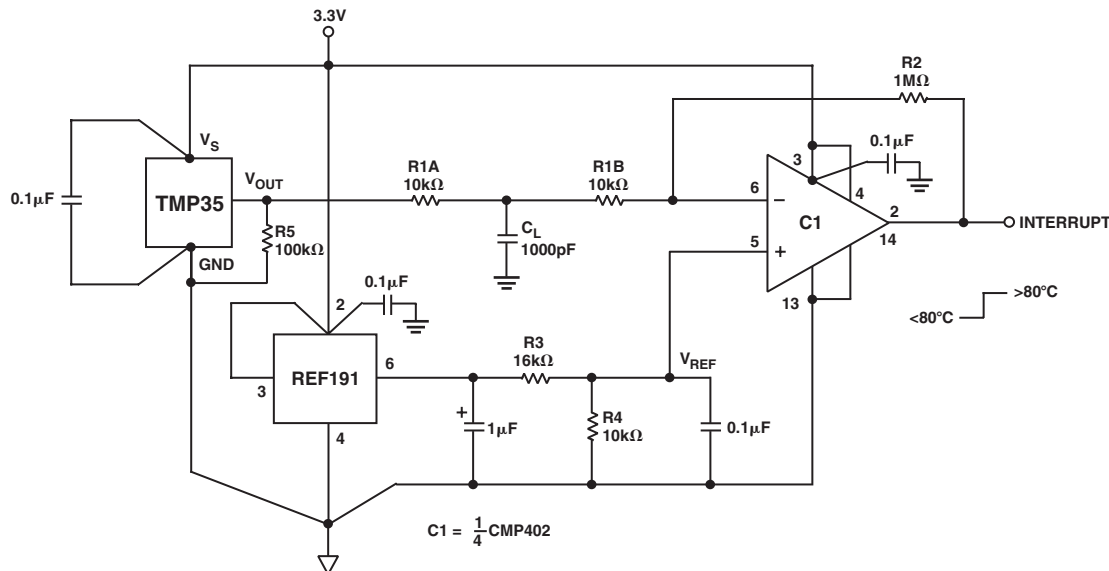

Figure 7. Pentium Overtemperature Interrupt Generator

Pentium is a registered trademark of Intel Corporation.

Thermocouple Signal Conditioning with Cold-Junction Compensation

The circuit in Figure 8 conditions the output of a Type K thermocouple, while providing cold-junction compensation for temperatures between 0°C and 250°C. The circuit operates from single 3.3 V to 5.5 V supplies and has been designed to produce an output voltage transfer characteristic of 10 mV/°C.

A Type K thermocouple exhibits a Seebeck coefficient of approximately 41 μV/°C; therefore, at the cold junction, the TMP35, with a temperature coefficient of 10 mV/°C, is used with R1 and R2 to introduce an opposing cold-junction temperature coefficient of -41 μV/°C. This prevents the isothermal, cold-junction connection between the circuit's PCB tracks and the thermocouple's wires from introducing an error in the measured temperature. This compensation works extremely well for circuit ambient temperatures in the range of 20°C to 50°C. Over a 250°C measurement temperature range, the thermocouple produces an output voltage change of 10.151 mV. Since the required circuit's output full-scale voltage is 2.5 V, the gain of the circuit is set to 246.3. Choosing R4 equal to 4.99 kΩ sets R5 equal to 1.22 MΩ. Since the closest 1% value for R5 is 1.21 MΩ, a 50 kΩ potentiometer is used with R5 for fine trim of the full-scale output voltage. Although the OP193 is a superior single-supply, micropower operational amplifier, its output stage is not rail-to-rail; as such, the 0°C output voltage level is 0.1 V. If this circuit were to be digitized by a single-supply ADC, the ADC's common should be adjusted to 0.1 V accordingly.

Using TMP3x Sensors in Remote Locations

In many industrial environments, sensors are required to operate in the presence of high ambient noise. These noise sources take on many forms; for example, SCR transients, relays, radio transmitters, arc welders, ac motors, and so on. They may also be used at considerable distances from the signal conditioning circuitry. These high noise environments are very typically in the form of electric fields, so the voltage output of the temperature sensor can be susceptible to contamination from these noise sources.

TMP35/TMP36/TMP37

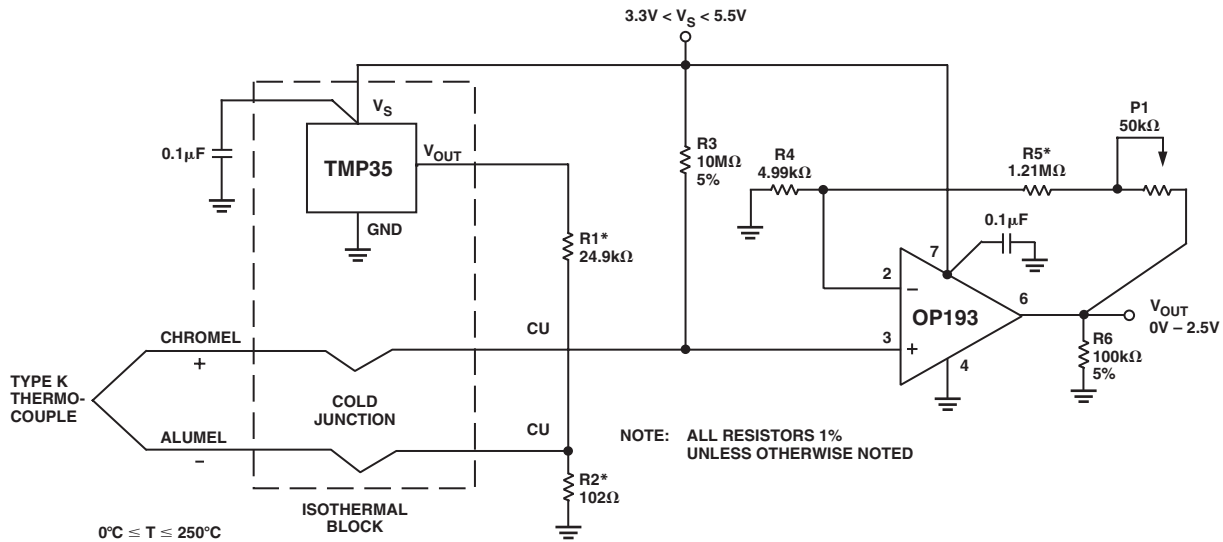

Figure 8. A Single-Supply, Type K Thermocouple Signal Conditioning Circuit with Cold-Junction Compensation

Illustrated in Figure 9 is a way to convert the output voltage of a TMP3x sensor into a current to be transmitted down a long twisted-pair shielded cable to a ground referenced receiver. The temperature sensors do not possess the capability of high output current operation; thus, a garden variety PNP transistor is used to boost the output current drive of the circuit. As shown in the table, the values of R2 and R3 were chosen to produce an arbitrary full-scale output current of 2 mA. Lower values for the full-scale current are not recommended. The minimum-scale output current produced by the circuit could be contaminated by nearby ambient magnetic fields operating in the vicinity of the circuit/cable pair. Because of the use of an external transistor, the minimum recommended operating voltage for this circuit is 5 V. Note, to minimize the effects of EMI (or RFI), both the circuit's and the temperature sensor's supply pins are bypassed with good quality, ceramic capacitors.

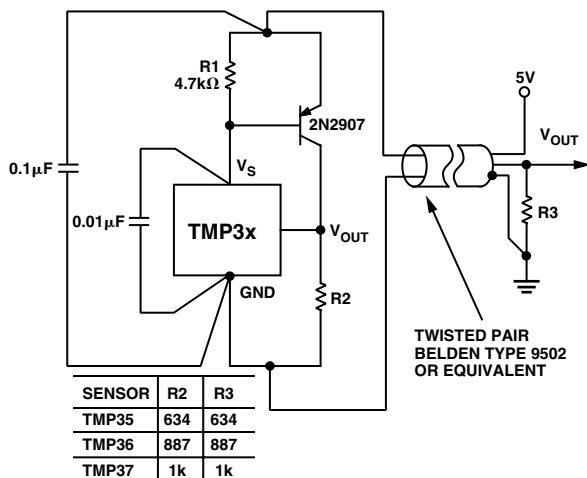

Figure 9. A Remote, 2-Wire Boosted Output Current Temperature Sensor

A Temperature to 4–20 mA Loop Transmitter

In many process control applications, 2-wire transmitters are used to convey analog signals through noisy ambient environments. These current transmitters use a “zero-scale” signal current of 4 mA that can be used to power the transmitter’s signal conditioning circuitry. The “full-scale” output signal in these transmitters is 20 mA.

A circuit that transmits temperature information in this fashion is illustrated in Figure 10. Using a TMP3x as the temperature sensor, the output current is linearly proportional to the temperature of the medium. The entire circuit operates from the 3 V output of the REF193. The REF193 requires no external trimming for two reasons: (1) the REF193’s tight initial output voltage tolerance and (2) the low supply current of TMP3x, the OP193 and the REF193. The entire circuit consumes less than 3 mA from a total budget of 4 mA. The OP193 regulates the output current to satisfy the current summation at the noninverting node of the OP193. A generalized expression for the KCL equation at the OP193’s Pin 3 is given by:

$$I_{OUT} = \left(\frac{1}{R7} \right) \times \left(\frac{TMP3x \times R3}{R1} + \frac{V_{REF} \times R3}{R2} \right)$$

For each of the three temperature sensors, the table below illustrates the values for each of the components, P1, P2, and R1–R4:

Table II. Circuit Element Values for Loop Transmitter

Sensor	R1(Ω)	P1(Ω)	R2(Ω)	P2(Ω)	R3(Ω)	R4(Ω)
TMP35	97.6 k	5 k	1.58 M	100 k	140 k	56.2 k
TMP36	97.6 k	5 k	931 k	50 k	97.6 k	47 k
TMP37	97.6 k	5 k	10.5 k	500	84.5 k	8.45 k

TMP35/TMP36/TMP37

The 4 mA offset trim is provided by P2, and P1 provides the circuit's full-scale gain trim at 20 mA. These two trims do not interact because the noninverting input of the OP193 is held at a virtual ground. The zero-scale and full-scale output currents of the circuit are adjusted according to the operating temperature range of each temperature sensor. The Schottky diode, D1, is required in this circuit to prevent loop supply power-on transients from pulling the noninverting input of the OP193 more than 300 mV below its inverting input. Without this diode, such transients could cause phase reversal of the operational amplifier and possible latchup of the transmitter. The loop supply voltage compliance of the circuit is limited by the maximum applied input voltage to the REF193 and is from 9 V to 18 V.

A Temperature to Frequency Converter

Another common method of transmitting analog information from a remote location is to convert a voltage to an equivalent in the frequency domain. This is readily done with any of the low cost, monolithic voltage-to-frequency converters (VFCs) available. These VFCs feature a robust, open-collector output transistor for easy interfacing to digital circuitry. The digital signal produced by the VFC is less susceptible to contamination from external noise sources and line voltage drops because the only important information is the frequency of the digital signal. As long as the conversions between temperature and frequency are done accurately, the temperature data from the sensors can be reliably transmitted.

The circuit in Figure 11 illustrates a method by which the outputs of these temperature sensors can be converted to a frequency using the AD654. The output signal of the AD654 is a square wave that is proportional to the dc input voltage across Pins 4 and 3. The transfer equation of the circuit is given by:

$$f_{OUT} = \left(\frac{V_{TMP} - V_{OFFSET}}{10 \times (R_T \times C_T)} \right)$$

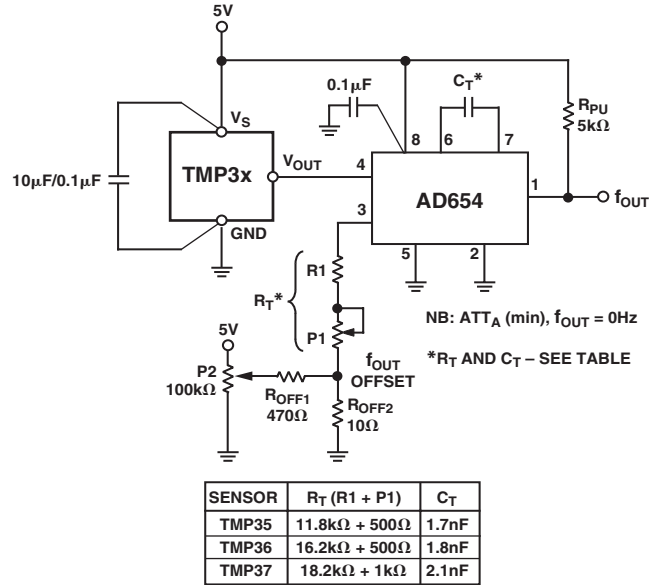

Figure 11. A Temperature-to-Frequency Converter

An offset trim network (f_{OUT} OFFSET) is included with this circuit to set f_{OUT} at 0 Hz when the temperature sensor's minimum output voltage is reached. Potentiometer P1 is required to calibrate the absolute accuracy of the AD654. The table in Figure 11 illustrates the circuit element values for each of the three sensors. The nominal offset voltage required for 0 Hz output from the TMP35 is 50 mV; for the TMP36 and TMP37, the offset voltage required is 100 mV. In all cases for the circuit values shown, the output frequency transfer characteristic of the circuit was set at 50 Hz/°C. At the receiving end, a frequency-to-voltage converter (FVC) can be used to convert the frequency back to a dc voltage for further processing. One such FVC is the AD650.

For complete information on the AD650 and AD654, please consult the individual data sheets for those devices.

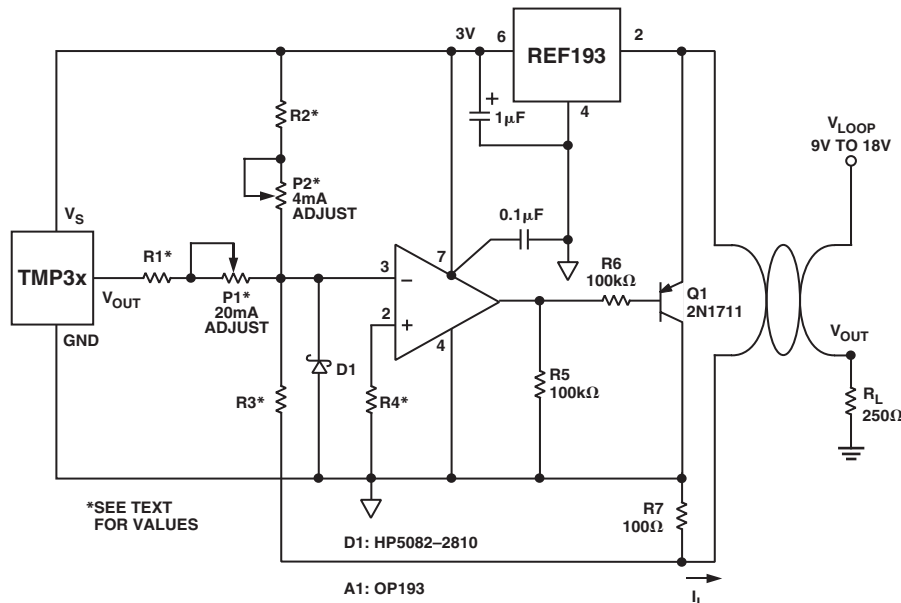

Figure 10. A Temperature to 4-to-20 mA Loop Transmitter

TMP35/TMP36/TMP37

Driving Long Cables or Heavy Capacitive Loads

Although the TMP3x family of temperature sensors is capable of driving capacitive loads up to 10,000 pF without oscillation, output voltage transient response times can be improved with the use of a small resistor in series with the output of the temperature sensor, as shown in Figure 12. As an added benefit, this resistor forms a low-pass filter with the cable's capacitance, which helps to reduce bandwidth noise. Since the temperature sensor is likely to be used in environments where the ambient noise level can be very high, this resistor helps to prevent rectification by the devices of the high frequency noise. The combination of this resistor and the supply bypass capacitor offers the best protection.

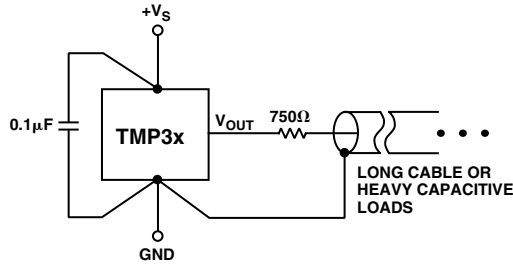

Figure 12. Driving Long Cables or Heavy Capacitive Loads

Commentary on Long-Term Stability

The concept of long-term stability has been used for many years to describe by what amount an IC's parameter would shift during its lifetime. This is a concept that has been typically applied to both voltage references and monolithic temperature sensors. Unfortunately, integrated circuits cannot be evaluated at room temperature (25°C) for 10 years or so to determine this shift. As a result, manufacturers very typically perform accelerated lifetime testing of integrated circuits by operating ICs at elevated temperatures (between 125°C and 150°C) over a shorter period of time (typically, between 500 and 1000 hours).

As a result of this operation, the lifetime of an integrated circuit is significantly accelerated due to the increase in rates of reaction within the semiconductor material.

TMP35/TMP36/TMP37

OUTLINE DIMENSIONS

3-Pin Plastic Header-Style Package [TO-92] (TO-92)

Dimensions shown in inches and (millimeters)

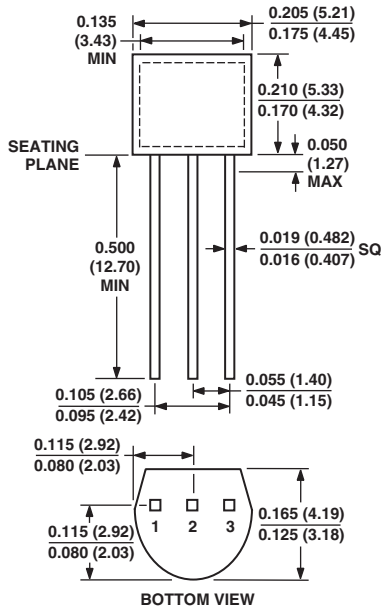

COMPLIANT TO JEDEC STANDARDS TO-226AA
CONTROLLING DIMENSIONS ARE IN INCHES; MILLIMETERS DIMENSIONS (IN PARENTHESES) ARE ROUNDED-OFF EQUIVALENTS FOR REFERENCE ONLY AND ARE NOT APPROPRIATE FOR USE IN DESIGN

8-Lead Standard Small Outline Package [SOIC] Narrow Body (RN-8)

Dimensions shown in millimeters and (inches)

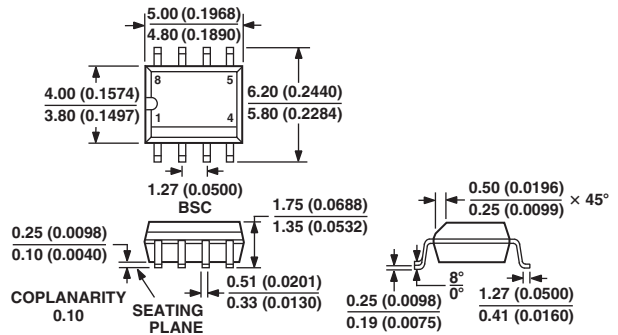

COMPLIANT TO JEDEC STANDARDS MS-012AA
CONTROLLING DIMENSIONS ARE IN MILLIMETERS; INCH DIMENSIONS (IN PARENTHESES) ARE ROUNDED-OFF MILLIMETER EQUIVALENTS FOR REFERENCE ONLY AND ARE NOT APPROPRIATE FOR USE IN DESIGN

5-Lead Plastic Surface-Mount Package [SOT-23] (RT-5)

Dimensions shown in millimeters

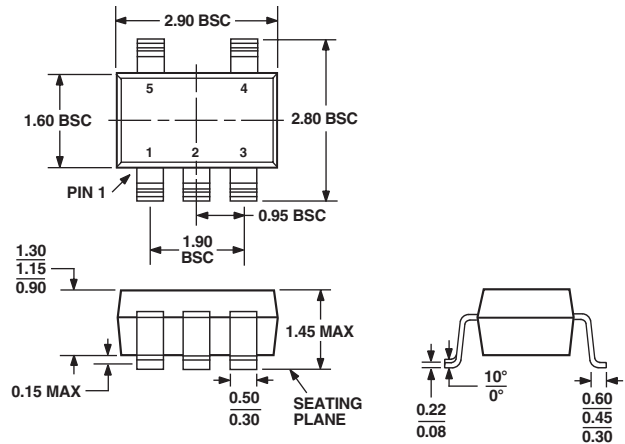

COMPLIANT TO JEDEC STANDARDS MO-178AA

Revision History

Location

Page

10/02—Data Sheet changed from REV. B to REV. C.

Deleted text from Commentary on Long-Term Stability section 13

Update OUTLINE DIMENSIONS 14

